

JSW 3AL gjutjärn självsugande jetpump

Artikelnr **Beteckning**

103838 JSW 3AL:2,2/3x400/G32/G25

Installation

Vikt 28,4 kg

Styrning Manuell

Ansl. in G32 inv

Ansl. ut G25 inv

Övrigt

Max Tryck 64 mVp

Max Flöde 160,0 l/min

Elektrisk Data

Effekt 2,20 kW

Märkström 5,4 A

Spänning 3x400

Pedrollo JSW självsugande jetpumpar pumpar rent vatten för hushålls- och trädgårdsapplikationer. Självsugande betyder att pumpen kan pumpa exempelvis från en grävbrunn, där luft kan finnas i slangen mellan hus och brunn.

En pålitlig serie pumpar med minimalt underhåll och lätt inkoppling. 3- och 1-fas utförande. Brett sortiment av flöde- och tryckförmåga som passar många anläggningar.

Tillverkad i Italien av Pedrollo till hög grad kvalitet, regelbundna produktuppdateringar och stilren design.

Applikationer:

vattenförsörjning, tvättanläggningar, tryckstegring, bevattning, transport av vatten, råvatten från brunn eller sjö.

Snabbfakta:

- Självsugande jetpump
- 3- och 1-fas utförande
- Hög tillförlitlighet



CHARACTERISTIC CURVES AND PERFORMANCE DATA

50 Hz n = 2900 min⁻¹ HS = 0 m

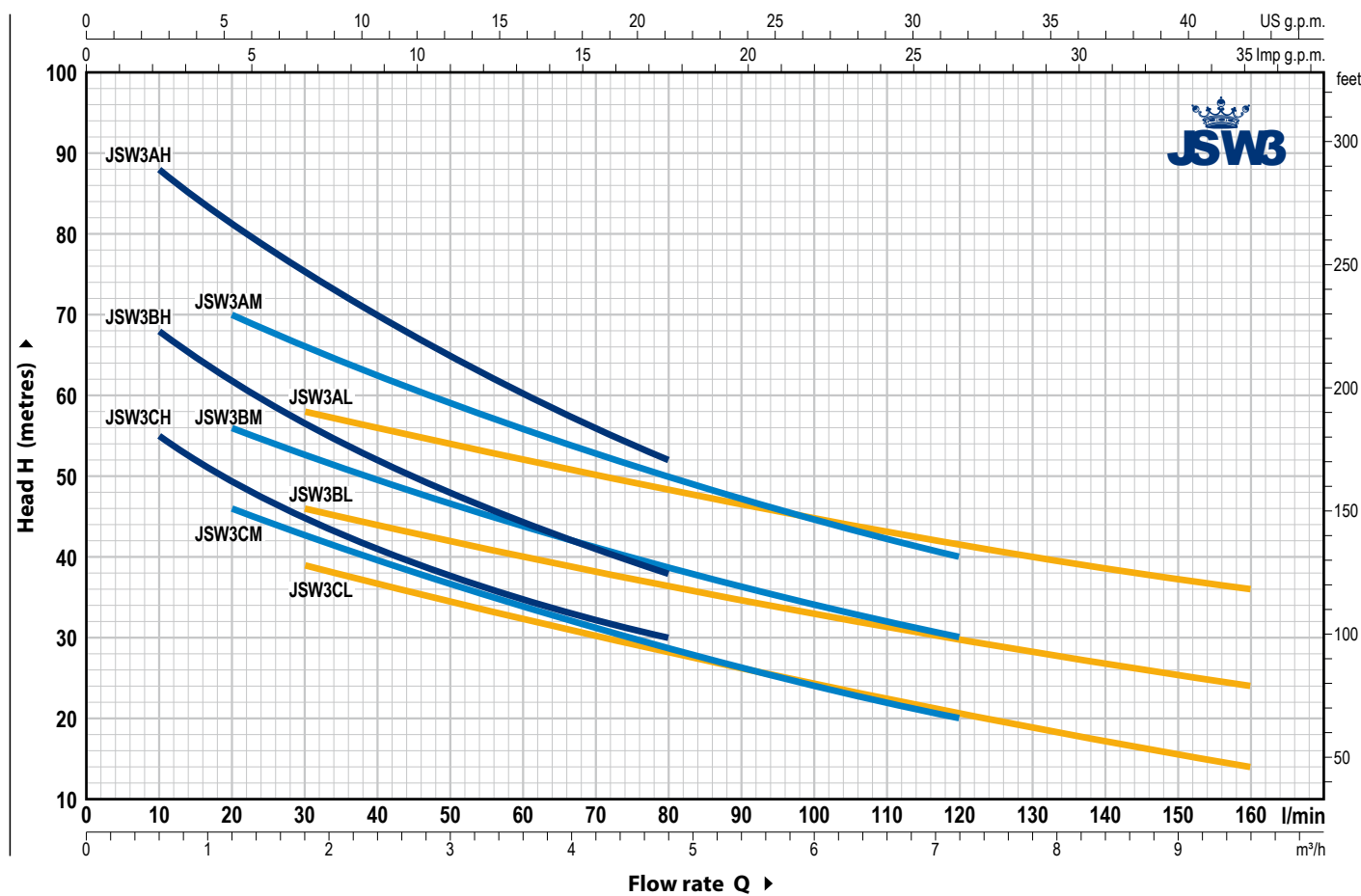

MODEL		POWER (P ₂)		▲	Q	m ³ /h															
Single-phase	Three-phase	kW	HP			0	0.6	1.2	1.8	2.4	3.0	3.6	4.2	4.8	6.0	7.2	8.4	9.6			
					l/min	0	10	20	30	40	50	60	70	80	100	120	140	160			
JSWm 3CH	JSW 3CH	1.1	1.5	IE3	H metres	62	55	49	45	41	38	35	32	30							
JSWm 3BH	JSW 3BH	1.5	2			73	68	62	56.5	52	48	44	41	38							
JSWm 3AH	JSW 3AH	2.2	3			97	88	81	75	70	65	60.5	56	52							
JSWm 3CM	JSW 3CM	1.1	1.5			54	-	46	43	39.5	36.5	34	31	28.5	24	20					
JSWm 3BM	JSW 3BM	1.5	2			63	-	56	53	49.5	47.5	44	41	39	34	30					
JSWm 3AM	JSW 3AM	2.2	3			78	-	70	66	62	59	56	53	50	45	40					
JSWm 3CL	JSW 3CL	1.1	1.5			44	-	-	39	37	34	32	30	28	24	21	17	14			
JSWm 3BL	JSW 3BL	1.5	2			51	-	-	46	44	42	40	38	36	33	30	27	24			
JSWm 3AL	JSW 3AL	2.2	3			64	-	-	58	56	54	52	50	48	45	41.5	38.5	36			

Q = Flow rate H = Total manometric head HS = Suction height

Tolerance of characteristic curves in compliance with EN ISO 9906 Grade 3B.

▲ Three-phase motor efficiency class (IEC 60034-30-1)

STANDARD INSTALLATION

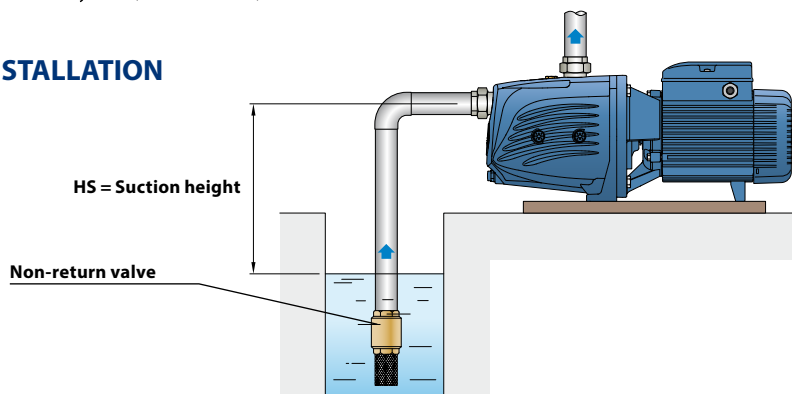

POS. COMPONENT CONSTRUCTION CHARACTERISTICS

1 PUMP BODY	Cast iron with an Epoxy Electro Coating treatment, with threaded ports in compliance with ISO 228/1				
2 BODY BACKPLATE	Cast iron				
3 NOZZLE ASSEMBLY	Noryl FE1520PW				
4 IMPELLER	Stainless steel AISI 304				
5 MOTOR SHAFT	Stainless steel AISI 431				
6 MECHANICAL SEAL	Seal	Shaft	Materials		
	<i>Model</i>	<i>Diameter</i>	<i>Stationary ring</i>	<i>Rotational ring</i>	<i>Elastomer</i>
	FN-18	Ø 18 mm	Graphite	Ceramic	NBR
7 BEARINGS	6204 ZZ / 6204 ZZ				
8 CAPACITOR	Pump	Capacitance			
	<i>Single-phase</i>	<i>(230 V or 240 V)</i>		<i>(110 V)</i>	
	JSWm 3C	31.5 µF - 450 VL	60 µF - 250 VL		
	JSWm 3B	45 µF - 450 VL	80 µF - 250 VL		
	JSWm 3A	50 µF - 450 VL	-		
9 ELECTRIC MOTOR	<p>JSWm: single-phase 230 V - 50 Hz with thermal overload protector incorporated into the winding. JSW: three-phase 230/400 V - 50 Hz.</p> <p>⇒ The three-phase pumps are fitted with high performance motors in class IE3 (IEC 60034-30-1)</p> <ul style="list-style-type: none"> - Insulation: class F - Protection: IP X4 				

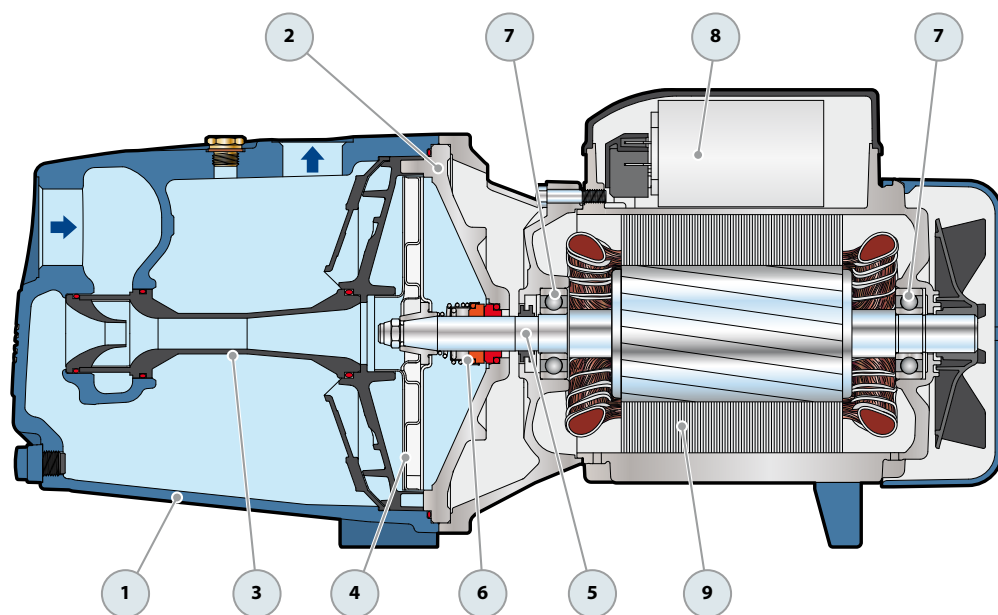

DIMENSIONS AND WEIGHT

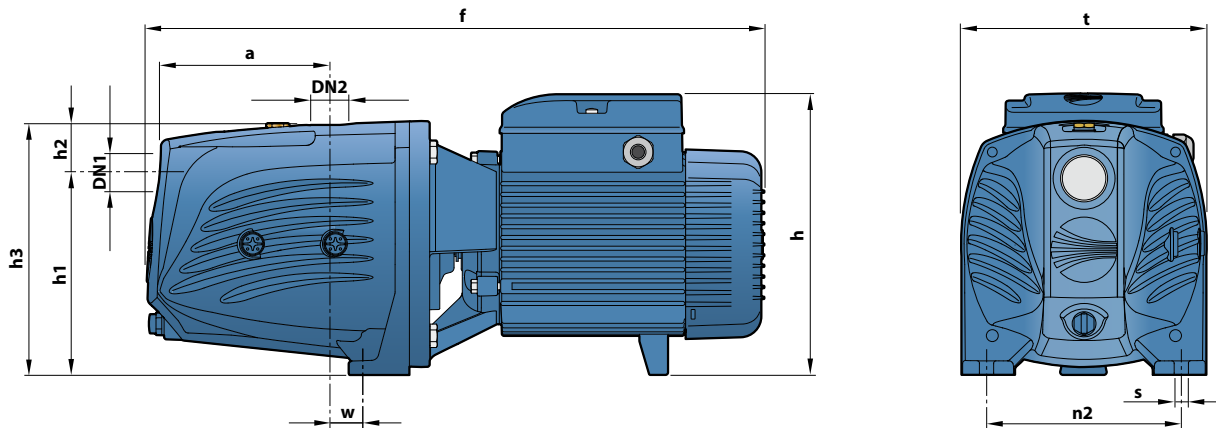

MODEL		PORTS		DIMENSIONS mm										kg	
Single-phase	Three-phase	DN1	DN2	a	f	h	h1	h2	h3	t	n2	w	s	1~	3~
JSWm 3CH	JSW 3CH	1¼"	1"	143	522	240	165	39	204	206	164	30	11	24.2	28.2
JSWm 3BH	JSW 3BH				25.5									25.4	
JSWm 3AH	JSW 3AH				28.2									28.0	
JSWm 3CM	JSW 3CM				24.4									24.4	
JSWm 3BM	JSW 3BM				25.6									25.5	
JSWm 3AM	JSW 3AM				28.0									28.2	
JSWm 3CL	JSW 3CL				24.4									24.3	
JSWm 3BL	JSW 3BL				25.6									25.5	
JSWm 3AL	JSW 3AL				28.2									28.2	

ABSORPTION

MODEL	VOLTAGE		
Single-phase	230 V	240 V	110 V
JSWm 3CH	8.1 A	7.8 A	16.2 A
JSWm 3BH	9.5 A	9.2 A	19.0 A
JSWm 3AH	12.7 A	12.4 A	-
JSWm 3CM	8.1 A	7.8 A	16.2 A
JSWm 3BM	9.7 A	9.4 A	19.4 A
JSWm 3AM	13.0 A	12.5 A	-
JSWm 3CL	8.1 A	7.8 A	16.2 A
JSWm 3BL	10.1 A	9.8 A	20.2 A
JSWm 3AL	13.6 A	13.1 A	-

MODEL	VOLTAGE					
Three-phase	230 V	400 V	690 V	240 V	415 V	720 V
JSW 3CH	5.2 A	3.0 A	1.7 A	5.0 A	2.9 A	1.7 A
JSW 3BH	6.0 A	3.5 A	2.0 A	5.8 A	3.4 A	1.9 A
JSW 3AH	8.8 A	5.1 A	2.9 A	8.5 A	4.9 A	2.8 A
JSW 3CM	5.2 A	3.0 A	1.7 A	5.0 A	2.9 A	1.7 A
JSW 3BM	6.0 A	3.5 A	2.0 A	5.8 A	3.4 A	1.9 A
JSW 3AM	9.0 A	5.2 A	3.0 A	8.6 A	5.0 A	2.9 A
JSW 3CL	5.2 A	3.0 A	1.7 A	5.0 A	2.9 A	1.7 A
JSW 3BL	6.4 A	3.7 A	2.1 A	6.1 A	3.6 A	2.0 A
JSW 3AL	9.3 A	5.4 A	3.1 A	9.0 A	5.2 A	3.0 A

PALLETIZATION

MODEL		GROUPAGE	CONTAINER
Single-phase	Three-phase	n. pumps	n. pumps
JSWm 3CH	JSW 3CH	35	49
JSWm 3BH	JSW 3BH	35	49
JSWm 3AH	JSW 3AH	35	49
JSWm 3CM	JSW 3CM	35	49
JSWm 3BM	JSW 3BM	35	49
JSWm 3AM	JSW 3AM	35	49
JSWm 3CL	JSW 3CL	35	49
JSWm 3BL	JSW 3BL	35	49
JSWm 3AL	JSW 3AL	35	49